

Dimension:

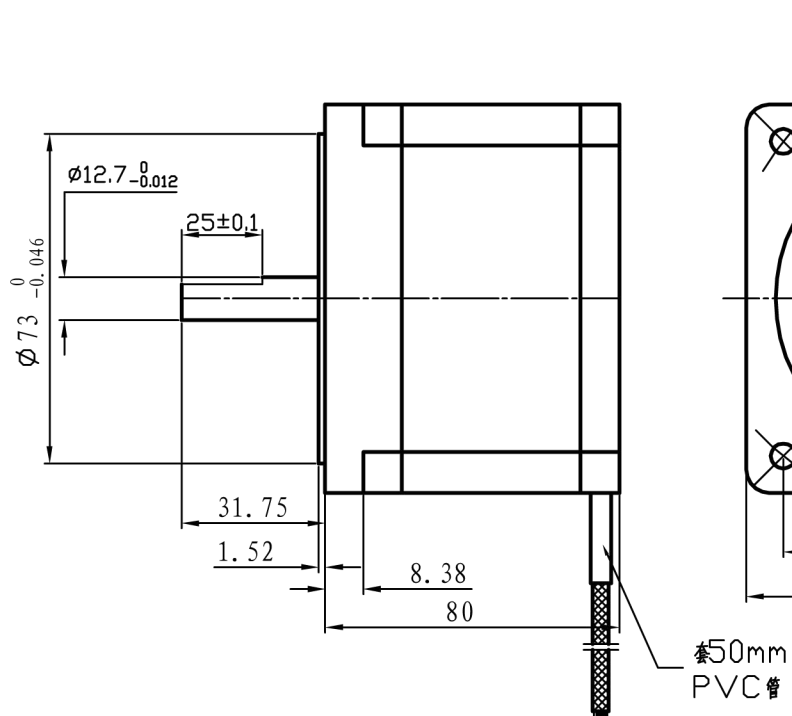

Wiring Diagram:

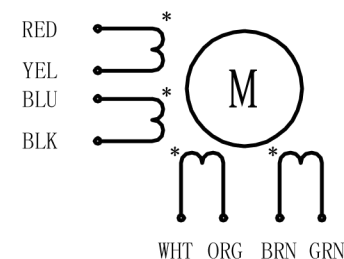

引出线从电机引出时套50mmPVC管

红黄蓝黑白橙棕绿

1007-AWG20#长500mm

Specifications:

PHASE	STEP ANGLE	CONNECTION STYLE	CURRENT	RESISTANCE	INDUCTANCE	HOLDING TORQUE	ROTOR INERTIA	WEIGHT
	DEG/STEP		A	ohms	mH	N. m	gcm ²	Kg
4	1.8	parallel	6	0.375	3.4	4.5	1400	2.3
		series	3	1.5	13.6			
		unipolar	4.24	0.75	3.4	3.2		

REV	ECN NO	DESCRIPTION	DRN	APP'D	DATE	DESIGN	DATE	P/N.
UNLESS OTHERWISE SPECIFIED TOLERANCES:						CHECK		TITLE SPECIFICATIONS
DECIMALS: .x ±0.5						APPD		USED ON 86HS45
ANGULAR: .xx ±0.25								DWG NO. REV
.xxx ±0.1						THIRD ANGLE PROJECTION	SCALE	深圳市雷赛智能控制股份有限公司
UNIT: mm							SHEET OF	
DO NOT SCALE DRAWING								