

Dimension: (Unit: mm)

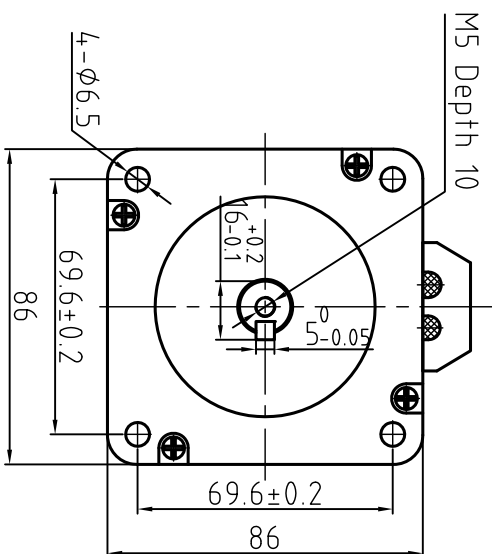

Motor Connections

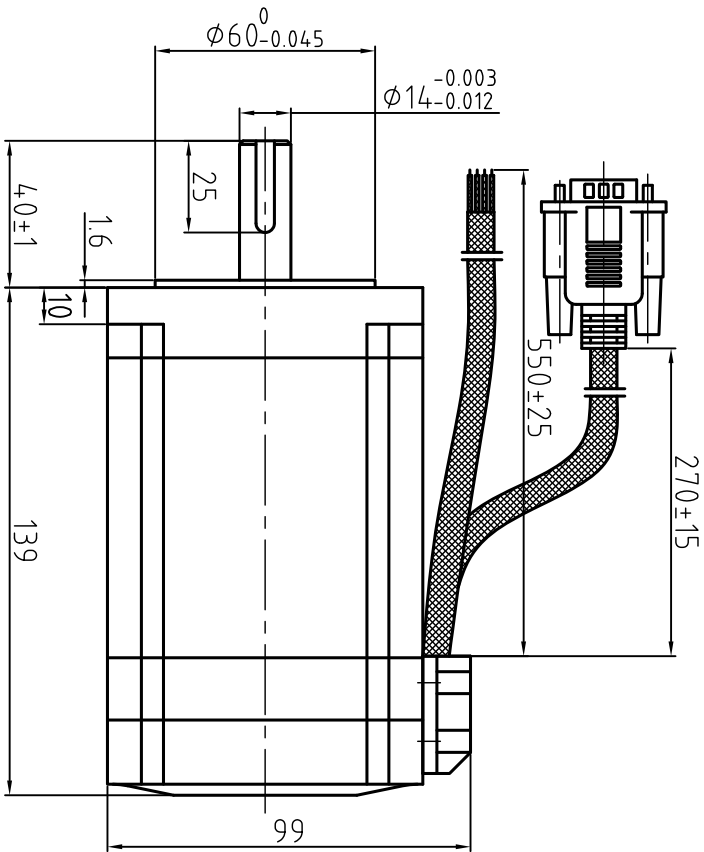
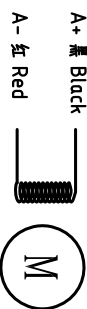

B+ Yellow B- Blue

Encoder Signals

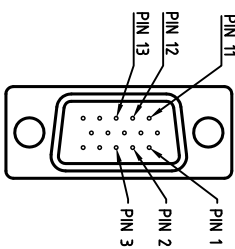

PIN	1	2	3	11	12	13
颜色	黑	红	白	黄	绿	蓝
定义	A+	VCC	GND	B+	B-	A-

Common Rating

Step angle	18°
Position accuracy	18±0.09°
Dielectric strength	1000VAC 1min
Insulation resistance	100MΩhm(500VDC)
Insulation class	B
Temp rise(Max)	80K
Radial play	Max:0.02mm(Load 4.50g)
Axial play	Max:0.08mm(Load 900g)

Specification

Current/phase	6.0 A
Voltage	3.2 V
DC Resistance/phase	±10% 0.55 Ω
Inductance/phase	±20% 4.2 mH
Holding torque	8 N·M
Inertia	2.8 kg·cm <sup>2</sup>
Weight	4 kg
Encoder Resolution	1000 cpr

设计 Designed	日期 Date	材料 Material	深圳市雷赛智能控制股份有限公司 SHENZHEN LEADSHINE TECHNOLOGY CO., LTD.
审核 Checked		第一角画法 First Angle projection	混合伺服电机
批准 Approved		重量/比例 Weight/Scale	86HBM80-1000
图号 Part No.		共 1 套 第 1 套 Sheet 1 of 1	图号 DWG. NO. LS-HBM86-04-5011-01

版本 Rev:	日期 Date	变更文件号 ECR NO.	变更内容 Revisions	设计 By
V1.0	13.7.8		初版	王平
V1.1	14.9.9		改进轴编码器	王平