

# 01 BLM Series Brushless DC Servo Motors

## Low-medium Voltage (24, 36 VDC)

Leadshine's BLM series motors are highly cost-effective brushless DC servo motors. Rated speed of BLM series motors is 3000 rpm (That of the 57BL180 is 4000 rpm). Standard model includes a 1000-line differential encoder (EA+/EA-, EB+/EB-), and Hall Sensors with standard Hall signals (U, V, W).

When driven by Leadshine ACS series servo drives, the BLM series motors can meet requirements of many applications requiring speed from as low as 1 rpm to as high as 4000 rpm. They are able to offer AC-servo-like performance, such as high speed, high precision, low motor noise and low heating performance, while at the cost of normal stepping systems. BLM series motors are flange mounted motors, and mounting is compatible with that of NEMA23 stepper motors. The 57BL180 is a screw mounted motor.

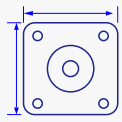
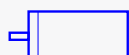
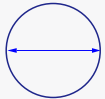
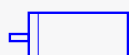

	<b>Frame Size</b>	57mm (NEMA23)		<b>Rated Power</b>	25 W, 50 W, 90 W, 130 W, 180 W
	<b>Diameter</b>	∅ 57mm		<b>Rated Power</b>	180 W

## 1.1 BLM Series Part Number

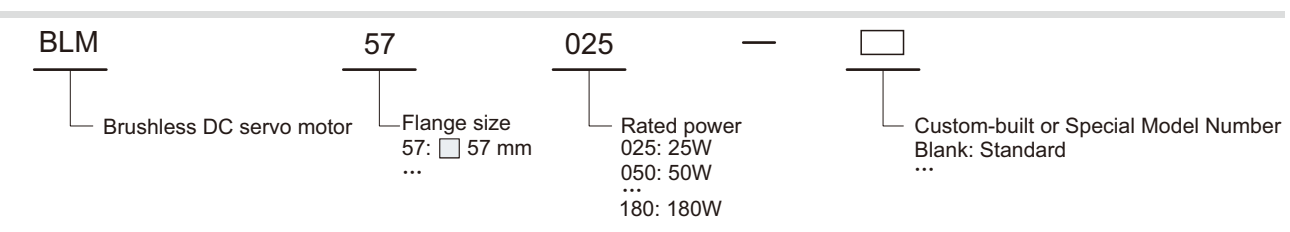

\* The 57BL180 is a screw mounted model, above rules inapplicable to this model.

## 1.2 BLM Series General Specifications

Winding connection: △ (Delta connection)  
 Hall Sensor: 120°  
 Pole Pairs (-): 2  
 Phase: 3  
 Shaft Radial Play: 0.025 mm  
 Shaft Axial Play: 0.025 mm@460g

Allowable radial load: 75N@20mm from the flange  
 Allowable axial load: 15N  
 Isolation Level: Class B  
 Isolation Strength: 500VDC for one minute  
 Isolation Resistance: 100M ohms

# 1.3 BLM Series Electrical Specifications



No.	Parameters	BLM57025	BLM57050	BLM57090	BLM57130	BLM57180	57BL180
1	Rated Voltage (VDC)	24	24	36	36	36	36
2	Rated Power (W)	25	50	90	130	180	180
3	Rated Torque (N.M)	0.08	0.16	0.29	0.41	0.57	0.43
4	Peak Torque (N.M)	0.24	0.48	0.87	1.23	1.71	1.27
5	Rated Speed (RPM)	3000	3000	3000	3000	3000	4000
6	Rated Current (A)	1.6	3	3.45	5.3	6.7	7
7	Peak Current (A)	4.8	9	10.35	15.9	20	20.5
8	Torque Const. (N.M/A)	0.05	0.053	0.084	0.078	0.085	0.063
9	Back EMF Const. (V/RPM)	5.2	5.55	8.8	8.2	8.9	6.6
10	Resistance (ohms)	1.73	0.88	1.35	0.63	0.9	0.35
11	Inductance (mH)	3.36	2.2	4.1	2.17	2	1
12	Inertia (kg x 10 <sup>-4</sup> )	30	75	119	173	230	230
13	Motor Length L (mm)	70	80	100	120	140	140
14	Mass (Kg)	0.25	0.5	0.75	1	1.25	1.25

# 1.4 BLM Series Mechanical Specifications

Unit: mm 1 inch = 25.4 mm

(a). Mechanical specification of the BLM57xxx series motors.

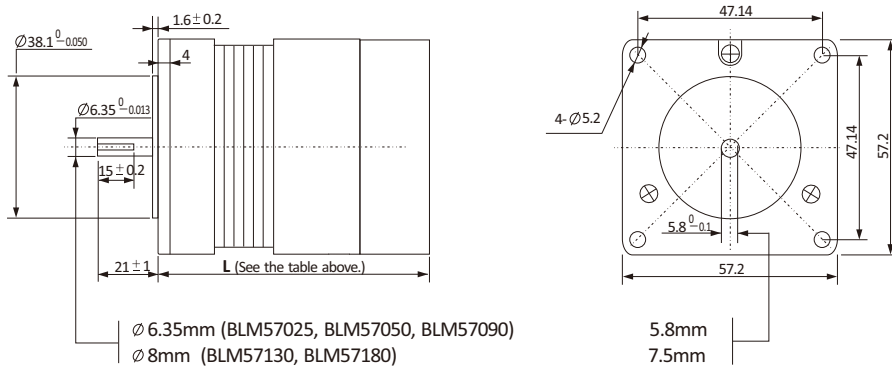

(b). Mechanical specification of the 57BL180.

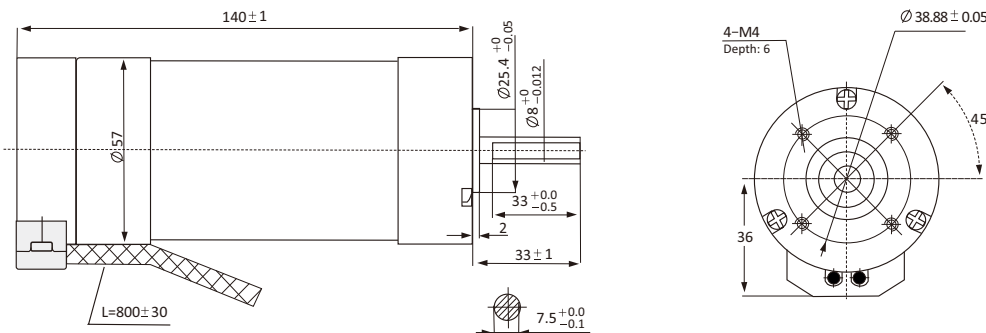

**Note:**

The thread depth for the M4 mounting holes on the face of the 57BL180 is 6.0 mm. Do not screw more than 6.0 mm as this will cause damage to the motor.

# 1.5 BLM Series Motor and Encoder Cables

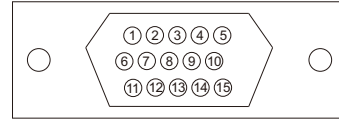
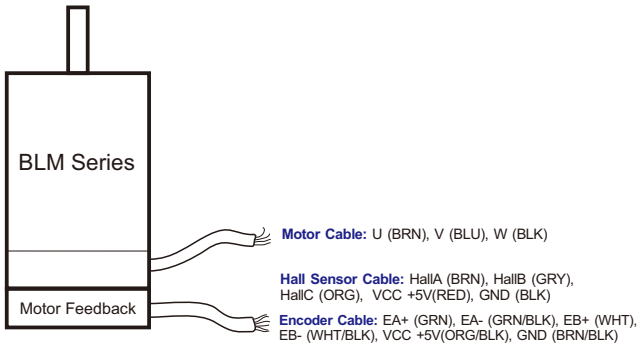

Motor Feedback (D-sub,15 pin, male)					
Pin	Description	Pin	Description	Pin	Description
1	EA+	6	NC	11	EA-
2	EB+	7	NC	12	EB-
3	GND	8	NC	13	Vcc
4	HallC	9	HallB	14	NC
5	HallA	10	NC	15	NC

**Note:** Standard connectors of the motor, encoder and hall sensor cables are for Leadshine's matching servo drives. They can be customized for your servo drives.

# 1.6 BLM Series Speed-Torque Curves

## Matching Drives

ACS306	ACS606
180 W	360 W

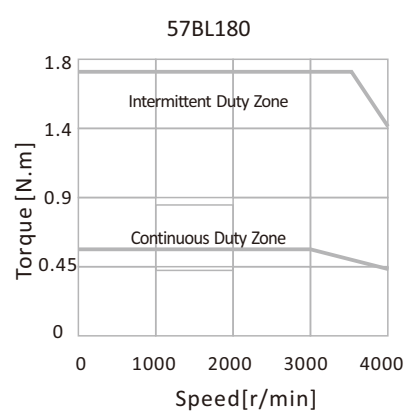
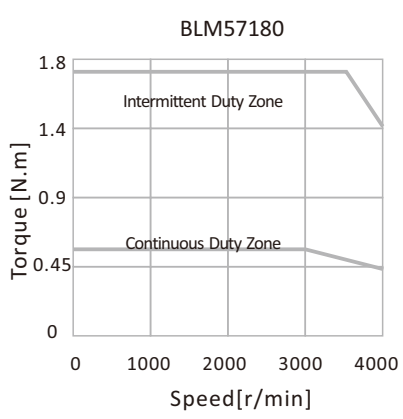
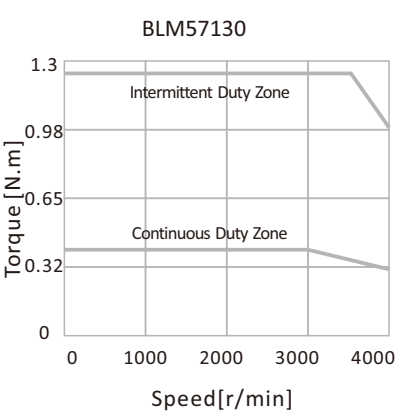
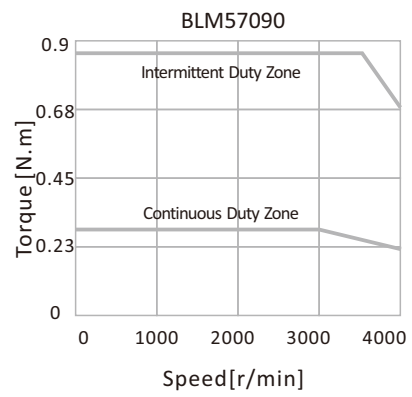
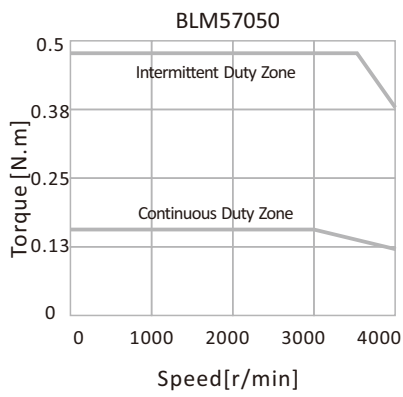
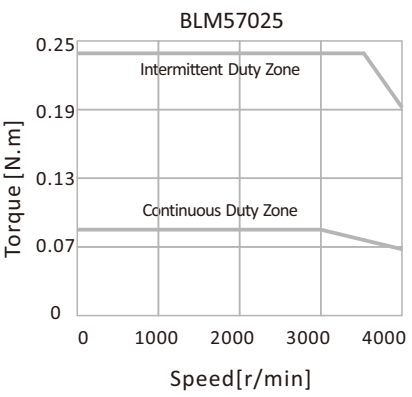

1.7

## BLM Series Order Information



Series	Model	Description
BLM Series Motors	BLM57025	Brushless DC Servo Motor, Rated Voltage: 24 VDC, Rated Power: 25W, Shaft Diameter: 6.35 mm
	BLM57050	Brushless DC Servo Motor, Rated Voltage: 24 VDC, Rated Power: 50W, Shaft Diameter: 6.35 mm
	BLM57090	Brushless DC Servo Motor, Rated Voltage: 36 VDC, Rated Power: 90W, Shaft Diameter: 6.35 mm
	BLM57130	Brushless DC Servo Motor, Rated Voltage: 36 VDC, Rated Power: 130W, Shaft Diameter: 8 mm
	BLM57180	Brushless DC Servo Motor, Rated Voltage: 36 VDC, Rated Power: 180W, Shaft Diameter: 8 mm
	57BL180	Brushless DC Servo Motor, Rated Voltage: 36 VDC, Rated Power: 180W, Shaft Diameter: 8 mm